

**Ersatzteilliste
Spare Parts List
Liste des pièces de rechange**

K 260/280

- 1.415-101.0 K 260 PLUS**
- 1.415-151.0 K 260M-VP-PL-WB**
- 1.415-152.0 K 260M-PL-WB**
- 1.415-251.0 K 280MS-PL-WB**

GRUPPE: 1.0 EINZELTEILE
GROUP: 1.0 PIECE PARTS
GRUPPE: 1.0 PIECES CONSTITUANTES

A1

K 260/280

GRUPPE: 1.0 EINZELTEILE
GROUP: 1.0 PIECE PARTS
GRUPPE: 1.0 PIECES CONSTITUANTES

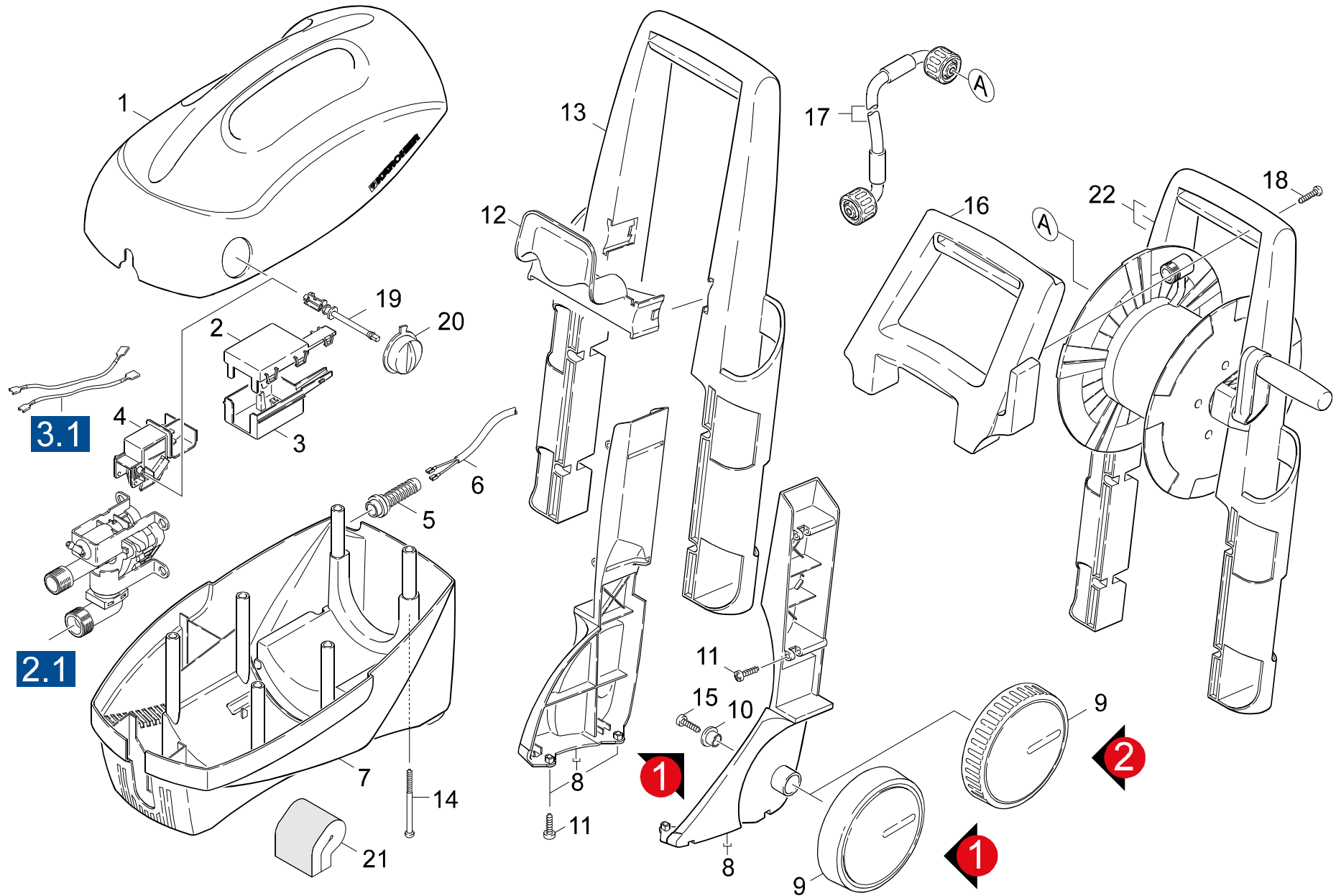

Symbolbeschreibung siehe M16 / symbol description see M16 / désignation de système voir M16 /

GRUPPE: 1.0 EINZELTEILE
 GROUP: 1.0 PIECE PARTS
 GROUPE: 1.0 PIECES CONSTITUANTES

C1

K 260/280

POS. ITM. POS.	BENNENNUNG DESCRIPTION DESIGNATION	TEILE-NR. PART-NO. NO.PIECE	STCK QTY. NBR.	POS. ITM. POS.	BENNENNUNG DESCRIPTION DESIGNATION	TEILE-NR. PART-NO. NO.PIECE	STCK QTY. NBR.
1	GEHAEUSE OBERTEIL / HOUSING / BOITIER	5.067-312.0	1	22	GRIFF KPL. K 280 MS / HANDLE / POIGNEE / 1.415-251.0	4.321-147.0	1
2	DECKEL E-KASTEN / COVER / COUVERCLE	5.064-024.0	1	23	KURBEL KPL. / CRANK / MANIVELLE	4.481-169.0	1
3	ELEKTROKASTEN / ELECTRIC BOX / COFFRE ELECTRIQUE	5.064-023.0	1				
4	SCHALTER KPL. / SWITCH / INTERRUPTEUR	6.630-117.0	1				
5	KABELTUELLE Z8,5 / CABLE BUSHING / PASSE CABLE	6.903-429.0	1				
6	KABEL M. STECKER / CABLE / CABLE	6.648-862.0	1				
7	GEHAEUSE UNTERTEIL / HOUSING / BOITIER	5.067-310.0	1				
8	ADAPTER PAAR K 260 / ADAPTER / ADAPTATEUR / 1.415-151.0 / -152.0 / -251.0	5.032-357.0	1				
9	RAD / WHEEL / ROUE VERSION 2/VERSION 2/VERSION 2 / 1.415-151.0 / -152.0 ab from a 17080 / -251.0	5.515-179.0	2				
9	RAD D 120/TROLLEY / WHEEL / ROUE / => 17079VERSION 1/VERSION 1/VERSION 1 / 1.415-152.0	9.036-153.0	2				
10	HUELSE / SLEEVE / DOUILLE / => 17079VERSION 1/VERSION 1/VERSION 1 / 1.415-152.0	5.110-697.0	2				
11	SCHR HI-LO 4,8X32 / SCREW / VIS	9.186-014.0	8				
12	HALTER F. SCHLAUCH / BRACKET / FIXATION / 1.415-151.0 / -152.0	5.044-069.0	1				
13	GRIFF K 502 M / HANDLE / POIGNEE / 1.415-151.0 / -152.0	5.321-663.0	1				
14	SCHRAUBE 4,2X 22 / SCREW / VIS	6.303-150.0	6				
15	SCHRAUBE 5 X 20 / SCREW / VIS / => 17079VERSION 1/VERSION 1/VERSION 1 / 1.415-152.0	7.303-108.0	2				
16	GRIFF / HANDLE / POIGNEE / 1.415-251.0	5.321-634.0	1				
17	HD-SCHLAUCH DN6 / HIGH PRESSURE HOSE / TUYAU FLEXIBLE HAUTE PRE. / 1.415-251.0	6.390-536.0	1				
18	SCHRAUBE 4 X 12 / SCREW / VIS / 1.415-251.0	7.303-095.0	2				
19	ACHSE LANG / AXLE / ESSIEU	5.105-296.0	1				
20	GRIFF SCHALTER / HANDLE / POIGNEE	5.321-563.0	1				
21	MATTE / MAT / PAILLASSON	5.176-008.0	1				

"=> xxxxxx" = bis Werknummer / up to serial No. / jusqu' au No. de fabr. / "xxxxxx =>" = ab Werknummer / from serial No. / a partir du No. de fabr. /

GRUPPE: 2.0 PUMPENSATZ
GROUP: 2.0 PUMP SET
GRUPPE: 2.0 JEU (ENSEMBLE) DE POMPE

A2

K 260/280

GRUPPE: 2.0 PUMPENSATZ
GROUP: 2.0 PUMP SET
GRUPPE: 2.0 JEU (ENSEMBLE) DE POMPE

GRUPPE: 2.1 STEUERGEHAEUSE
GROUP: 2.1 HOUSING
GRUPPE: 2.1 BOITIER

B2

K 260/280

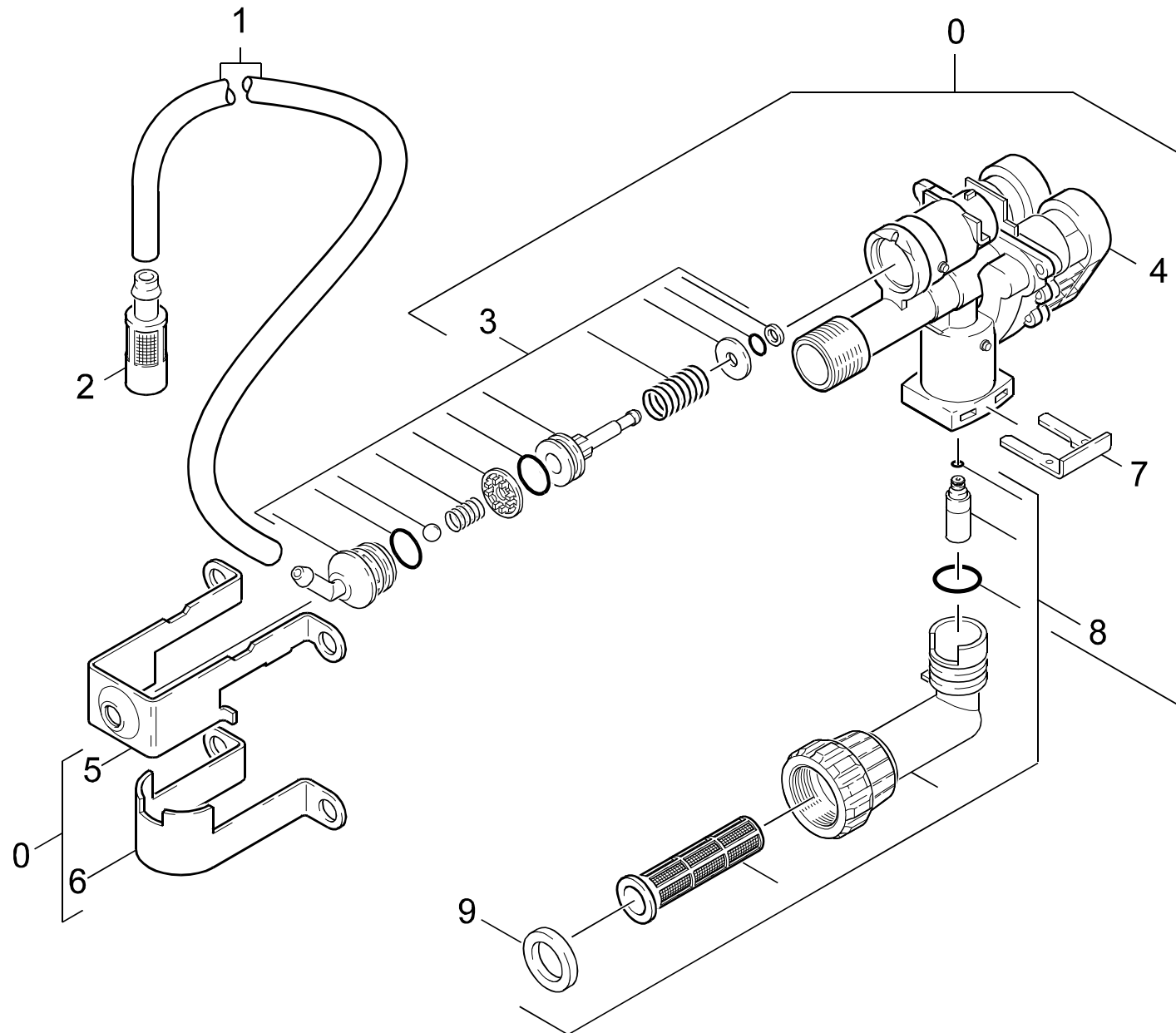

Symbolbeschreibung siehe M16 / symbol description see M16 / désignation de système voir M16 /

GRUPPE: 2.1 STEUERGEHAEUSE
GROUP: 2.1 HOUSING
GROUPE: 2.1 BOITIER

C2

K 260/280

POS.	BENNENUNG ITM. DESCRIPTION POS. DESIGNATION	TEILE-NR. PART-NO. NO.PIECE	STCK QTY. NBR.
0	ZYLINDERKOPF / CYLINDER HEAD / CULASSE	4.550-620.0	1
1	SCHLAUCH DN 5 / HOSE / TUYAU FLEXIBLE	6.388-216.0	1
	ALS METERWARE BESTELLEN/TO ORDER AS CUT GOODS/COMMANDE COMME MARCHANDISE AU METRE		
2	FILTER MIT GEWICHT / FILTER / FILTRE	5.731-609.0	1
3	ET-SET CH.-STEUERK. / SPARE PARTS SET / JEU DE PIECES DECHANGE	2.884-133.0	1
4	ZYLINDERKOPF KPL. / CYLINDER HEAD / CULASSE	4.550-507.0	1
5	BLECHTEIL / PLATE / TOLE	5.048-407.0	1
6	BLECHTEIL / PLATE / TOLE	5.048-408.0	1
7	KLAMMER / CLAMP / BRIDE DE FIXATION	5.048-406.0	1
8	SAUGDECKEL + SV / COVER / COUVERCLE	4.063-690.0	1
9	FLACHDICHTUNG / SEAL / GARNITURE PLATE	5.364-129.0	1

"=> xxxxxx" = bis Werknummer / up to serial No. / jusqu' au No. de fabr. / "xxxxxx =>" = ab Werknummer / from serial No. / a partir du No. de fabr. /

GRUPPE: 2.2 ZYLINDERKOPF
GROUP: 2.2 CYLINDER HEAD
GRUPPE: 2.2 CULASSE

D2

K 260/280

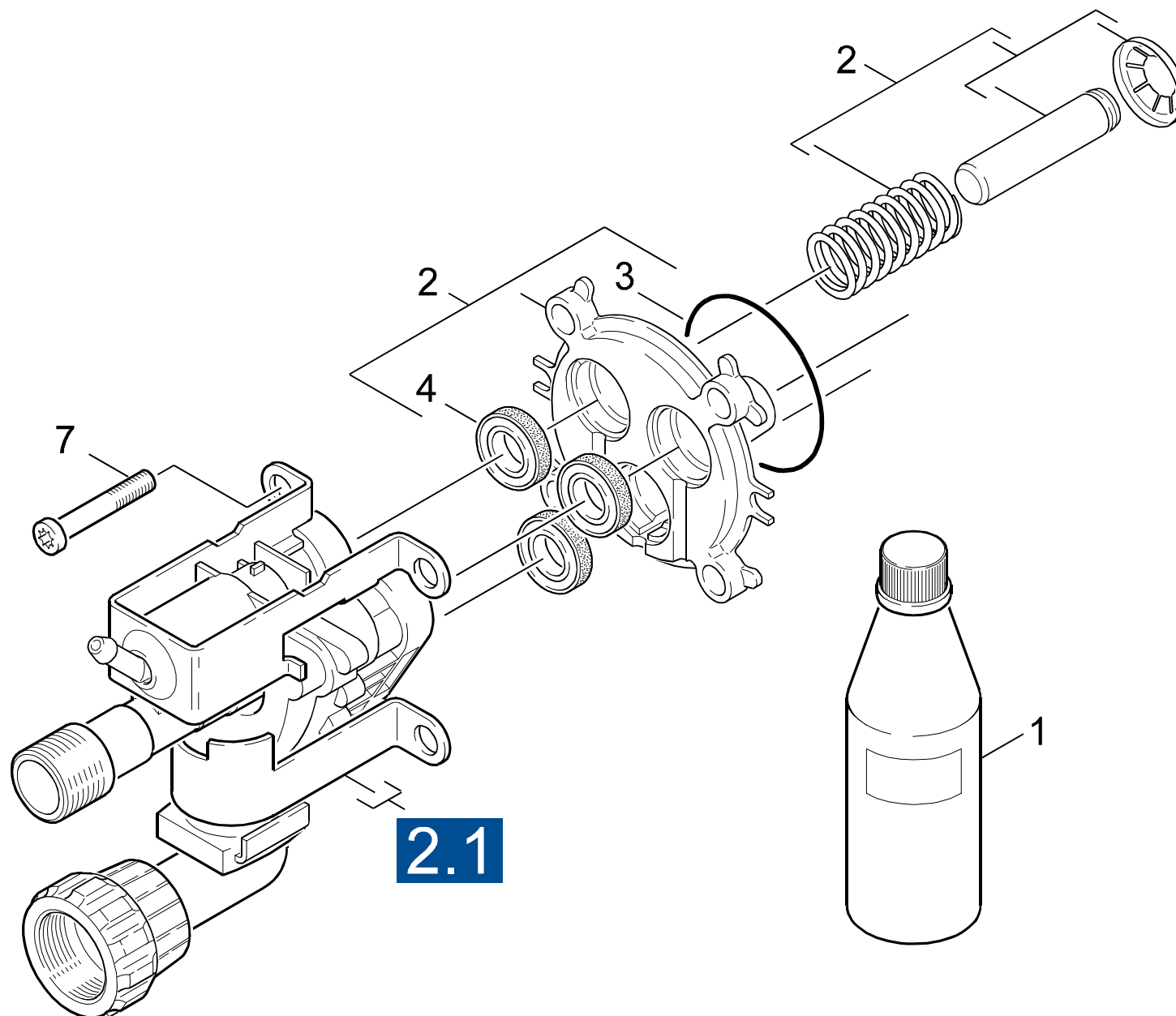

Symbolbeschreibung siehe M16 / symbol description see M16 / désignation de système voir M16 /

GRUPPE: 2.2 ZYLINDERKOPF
GROUP: 2.2 CYLINDER HEAD
GRUPPE: 2.2 CULASSE

E2

K 260/280

POS.	BENNENUNG	TEILE-NR.	STCK
ITM.	DESCRIPTION	PART-NO.	QTY.
POS.	DESIGNATION	NO.PIECE	NBR.
1	MOTORENOEL 1L / ENGINE OIL / HUILE (MOTEUR)	6.288-112.0	1
2	GERADSCHUBFUEHRUNG / HOUSING / BOITIER	4.060-283.0	1
3	O-RING 60,0 X 2,5 / GASKET / BAQUE D'ETANCHEITE	6.362-902.0	1
4	NUTRING 12X20X4/6 / GROOVED RING / JOINT A LEVRES	6.365-393.0	3
7	SCHRAUBE CE M 8X 40 / SCREW / VIS	6.303-144.0	4

"=> xxxxxx" = bis Werknummer / up to serial No. / jusqu' au No. de fabr. / "xxxxxx =>" = ab Werknummer / from serial No. / a partir du No. de fabr. /

GRUPPE: 3.0 MOTOR
GROUP: 3.0 MOTOR
GRUPPE: 3.0 MOTEUR

A3

K 260/280

GRUPPE: 3.0 MOTOR
GROUP: 3.0 MOTOR
GRUPPE: 3.0 MOTEUR

GRUPPE: 3.1 MOTOR
GROUP: 3.1 MOTOR
GRUPPE: 3.1 MOTEUR

B3

K 260/280

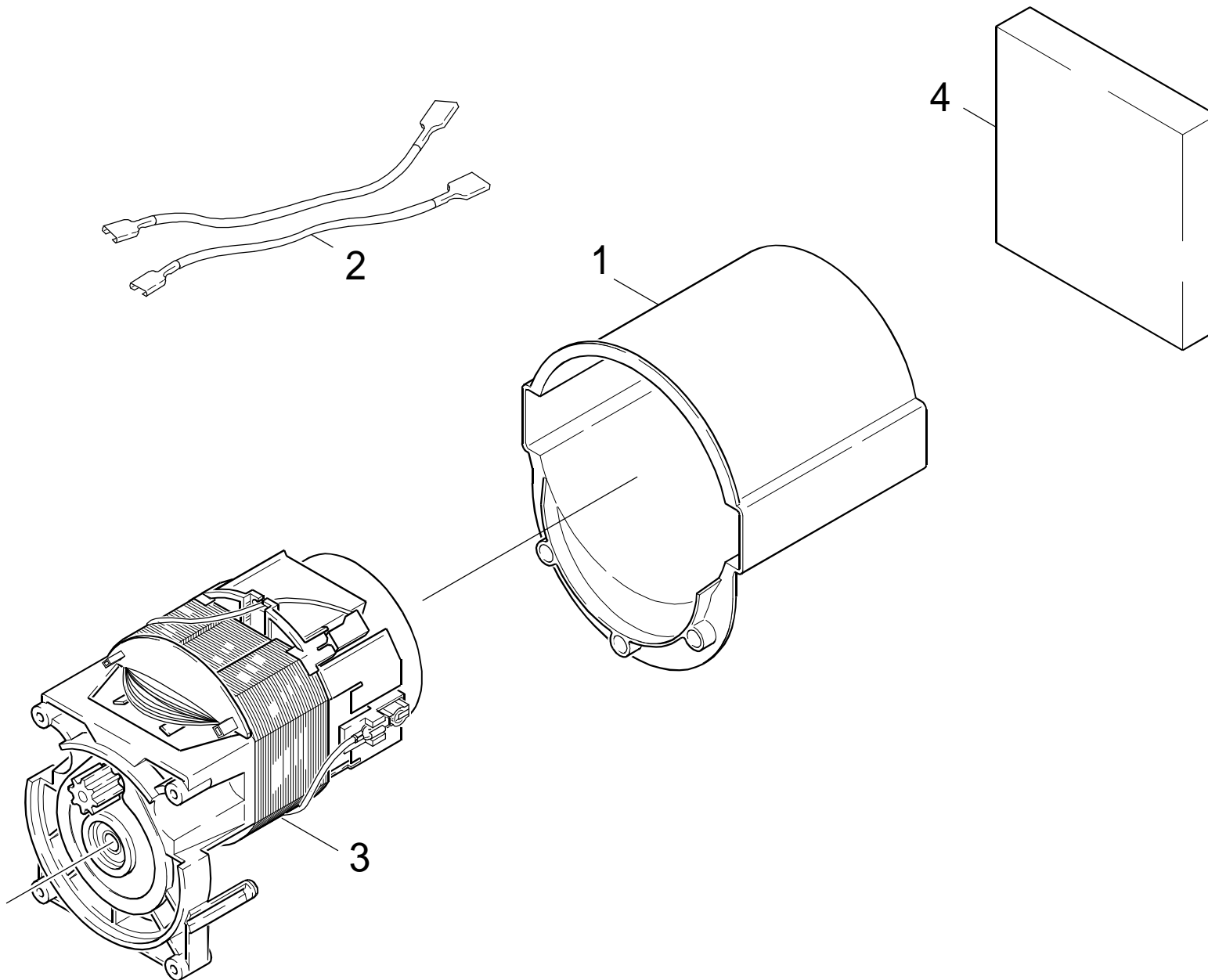

Symbolbeschreibung siehe M16 / symbol description see M16 / désignation de système voir M16 /

GRUPPE: 3.1 MOTOR
GROUP: 3.1 MOTOR
GROUPE: 3.1 MOTEUR

C3

K 260/280

POS.	BENNENNUNG	TEILE-NR.	STCK
ITM.	DESCRIPTION	PART-NO.	QTY.
POS.	DESIGNATION	NO.PIECE	NBR.
1	HAUBE MOTOR / COVER / CAPOT	5.066-999.0	1
2	KABELSATZ K260 / CABLE SET / JEU DE CABLES	2.820-165.0	1
3	ET-SET MOTOR KPL. / SPARE PARTS SET / JEU DE PIECES DECHANGE	2.883-959.0	1
4	ISOLIERMATTE K460 / INSULATING MAT / TAPIS ISOLANTE	5.673-088.0	1

"=> xxxxxx" = bis Werknummer / up to serial No. / jusqu' au No. de fabr. / "xxxxxx =>" = ab Werknummer / from serial No. / a partir du No. de fabr. /

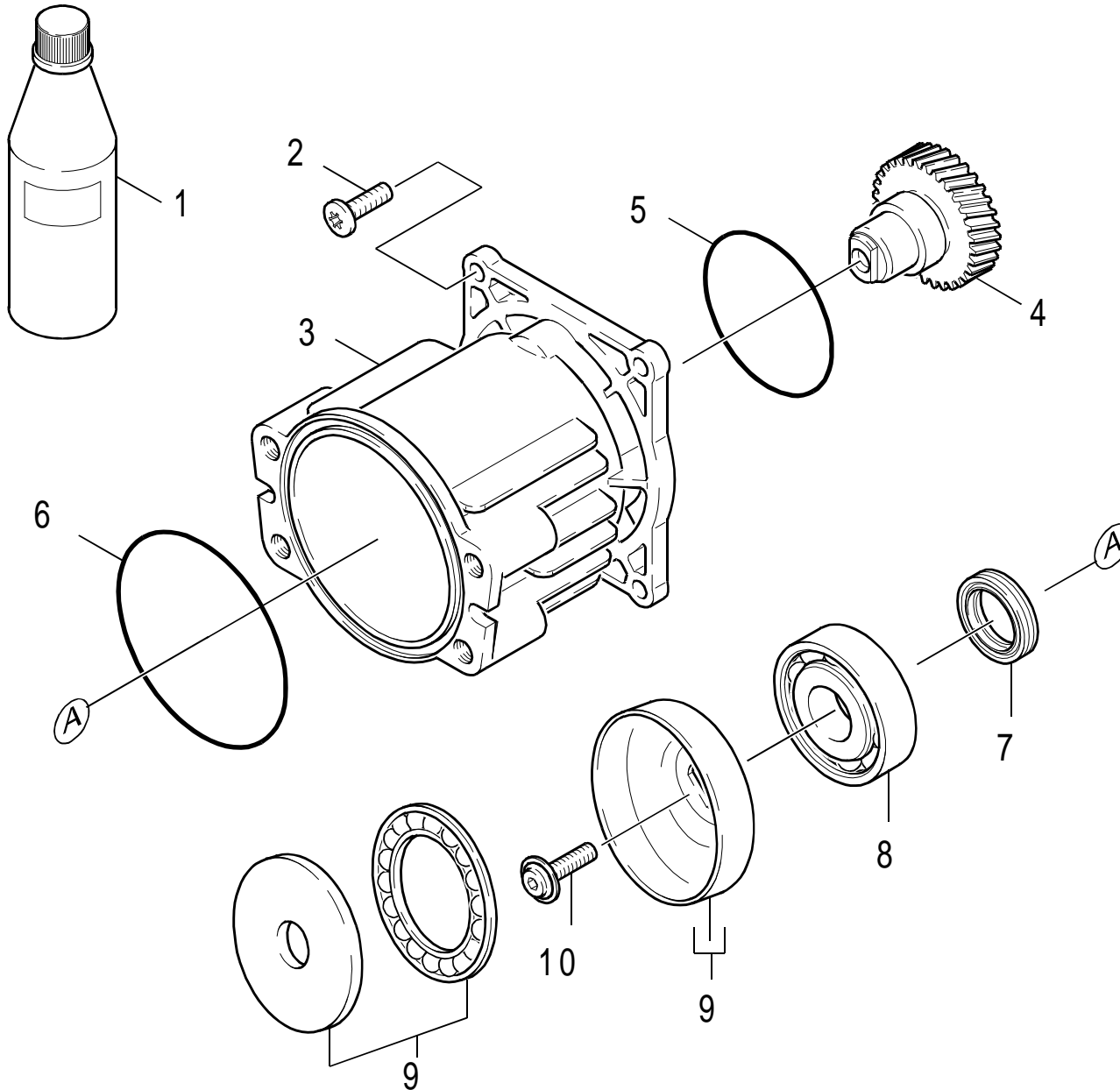

Symbolbeschreibung siehe M16 / symbol description see M16 / désignation de système voir M16 /

GRUPPE: 3.2 MOTOR
GROUP: 3.2 MOTOR
GRUPPE: 3.2 MOTEUR

E3

K 260/280

POS.	BENNENUNG	TEILE-NR.	STCK
ITM.	DESCRIPTION	PART-NO.	QTY.
POS.	DESIGNATION	NO.PIECE	NBR.
1	MOTORENOEL 1L / ENGINE OIL / HUILE (MOTEUR)	6.288-050.0	1
2	SCHRAUBE 5X20 / SCREW / VIS	6.303-187.0	4
3	GEHAEUSE GETRIEBE / HOUSING / BOITIER	5.093-182.0	1
4	STIRNZAHNRAD / GEAR WHEEL / ROUE D'ENGRENAGE	4.352-013.0	1
5	PROFILDICHTUNG / SEAL / ETOUPE PROFILE	5.365-179.0	1
6	O-RING 60,0 X 2,5 / GASKET / BAQUE D'ETANCHEITE	6.362-902.0	1
7	WELLENDI. 22X35X5 / ROTARY SHAFT SEAL / JOINT (ARBRE)	6.964-098.0	1
8	KUGELLAGER 6303 / BALL BEARING / ROULEMENT A BILLE	7.401-010.0	1
9	TAUMELSCHEIBE / SWASH PLATE / DISQUE EN NUTATION	6.401-266.0	1
10	ZYL.SCHR. M 6X 19 / CHEESE HEAD SCREW / VIS A TETE CYLINDR.	6.304-048.0	1

"=> xxxxxx" = bis Werknummer / up to serial No. / jusqu' au No. de fabr. / "xxxxxx =>" = ab Werknummer / from serial No. / a partir du No. de fabr. /

GRUPPE: 4.0 ZUBEHOER
GROUP: 4.0 ACCESSORIES
GRUPPE: 4.0 ACCESSOIRES

A4

K 260/280

GRUPPE: 4.0 ZUBEHOER
GROUP: 4.0 ACCESSORIES
GRUPPE: 4.0 ACCESSOIRES

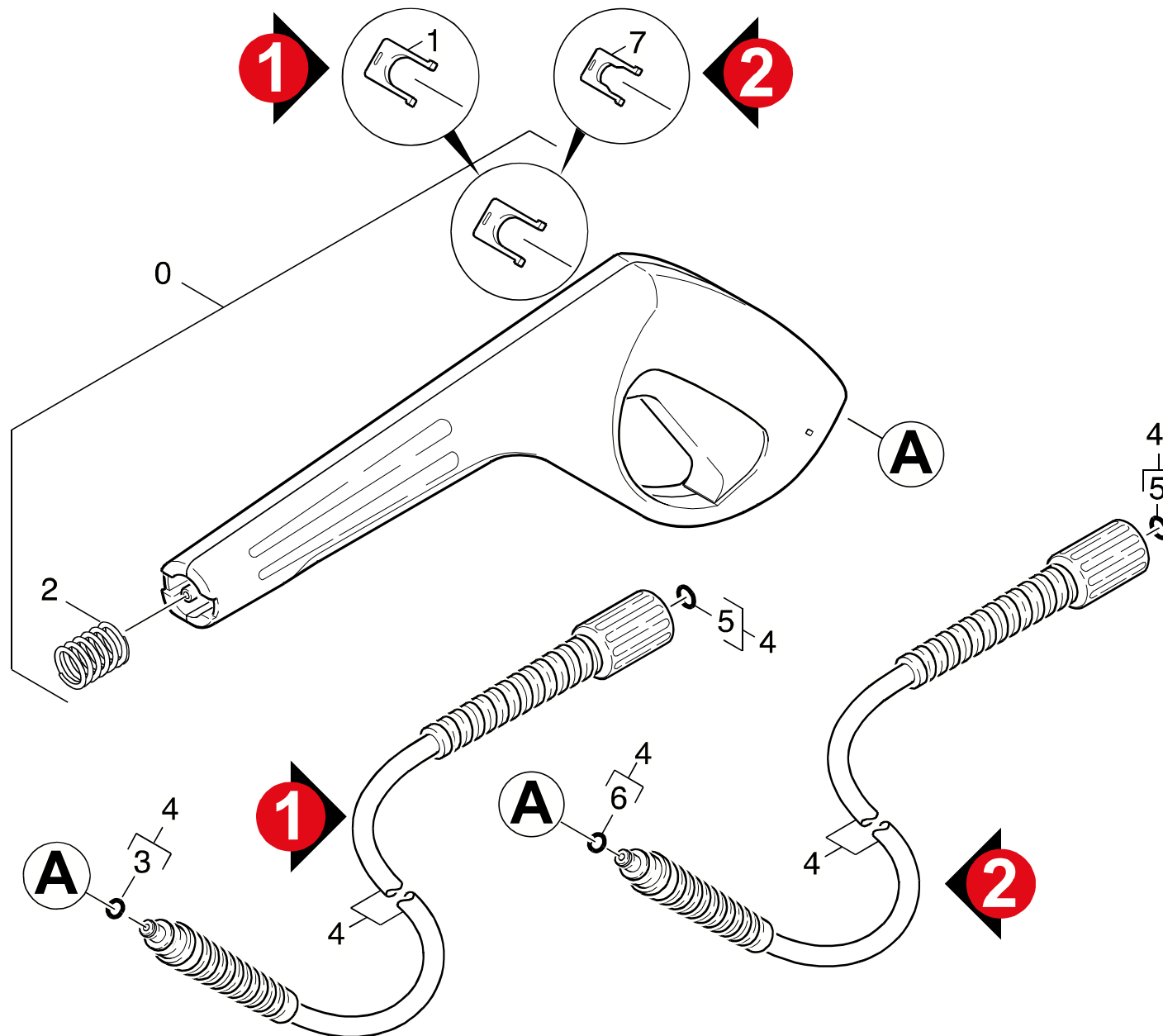

Symbolbeschreibung siehe M16 / symbol description see M16 / désignation de système voir M16 /

GRUPPE: 4.1 HANDSPRITZPISTOLE
GROUP: 4.1 TRIGGER GUN
GROUPE: 4.1 POIGNEE PISTOLET

C4

K 260/280

POS. ITM. POS.	BENNENUNG DESCRIPTION DESIGNATION	TEILE-NR. PART-NO. NO.PIECE	STCK QTY. NBR.
0	PISTOLE-M V1 / PISTOLE-M V1 / PISTOLE-M V1 VERSION 1 / 1.415-101.0 / -152.0	4.775-424.0	1
0	PISTOLE-M V1.1 / PISTOLE-M V1.1 / PISTOLE-M V1.1 VERSION 2 / 1.415-151.0 / -251.0	4.775-429.0	1
1	KLAMMER / CLAMP / BRIDE DE FIXATION VERSION 1 / 1.415-101.0 / -152.0	5.037-137.0	1
2	DRUCKFEDER / PRESSURE SPRING / RESSORT A PRESSION	5.332-464.0	1
3	O-RING KPL./1ST.-R. / GASKET / BAQUE D'ETANCHEITE / 1.415-151.0 / -251.0	6.363-031.0	1
4	HD-M-SCHL. 9/16MPA / HD-M-SCHL. 9/16MPA / HD-M-SCHL. 9/16MPA VERSION 2 / 1.415-151.0 / -251.0	6.390-463.0	1
4	HD-M-SCHL.7,5/14MPA / HD-M-SCHL.7,5/14MPA / HD-M-SCHL.7,5/14MPA	6.390-499.0	1
5	O-RINGSET / GASKET SET / JUE DE BAGUES D'ENTCHEITE	2.880-154.0	1
6	O-RING 6,75X 1,78 / GASKET / BAQUE D'ETANCHEITE	6.362-498.0	1
7	KLAMMER / CLAMP / BRIDE DE FIXATION VERSION 2 / 1.415-101.0 / -151.0 / -152.0 / -251.0	5.037-140.0	1

"=> xxxxxx" = bis Werknummer / up to serial No. / jusqu' au No. de fabr. / "xxxxxx =>" = ab Werknummer / from serial No. / a partir du No. de fabr. /

GRUPPE: 4.2 STRAHLROHR
GROUP: 4.2 JET PIPE
GRUPPE: 4.2 LANCE D'INCENDIE

D4

K 260/280

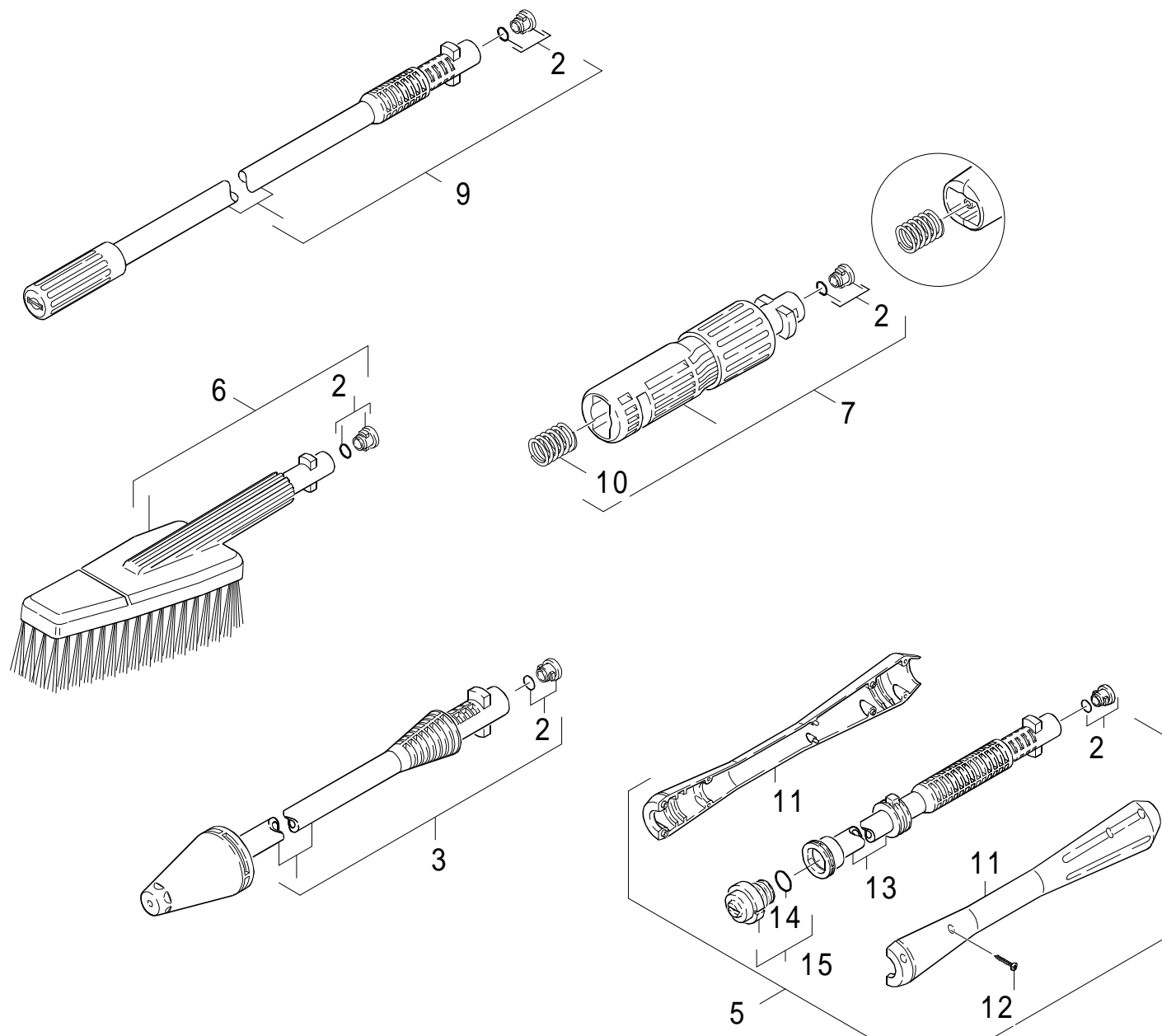

Symbolbeschreibung siehe M16 / symbol description see M16 / désignation de système voir M16 /

GRUPPE: 4.2 STRAHLROHR
GROUP: 4.2 JET PIPE
GROUPE: 4.2 LANCE D'INCENDIE

E4

K 260/280

POS. ITM. POS.	BENNENUNG DESCRIPTION DESIGNATION	TEILE-NR. PART-NO. NO.PIECE	STCK QTY. NBR.
2	ERSATZTEILSET / SPARE PARTS KIT / KIT DE PIECES	2.883-111.0	5
3	ROTORDUESE LP/027 K / ROTARY NOZZLE / BUSE JET ROTATIF	4.763-944.0	1
5	STRAHLROHR VP026 / JET PIPE / LANCE D'INCENDIE / 1.415-151.0 / -251.0	4.760-440.0	1
6	WASCHBUERSTE STARR / WASH BRUSH / BROSSSE / 1.415-151.0 / -251.0	6.903-276.0	1
7	ADAPTER /KAER. / ADAPTER / ADAPTATEUR	4.762-290.0	1
9	STRAHLROHR M.D.026 / JET PIPE / LANCE D'INCENDIE / 1.415-152.0	4.760-487.0	1
9	STRAHLROHR M.D.028 / JET PIPE / LANCE D'INCENDIE / 1.415-101.0	4.760-489.0	1
10	SCHRAUBENFEDER / HELICAL SPRING / RESSORT CYLINDRIQUE	5.332-249.0	1
11	GRIFFPAAR / HANDLES / BRANCHES POIGNEE / 1.415-151.0 / -251.0	5.321-445.0	1
12	LINSENSCHR. 4,2X 13 / OVAL HEAD SCREW / VIS A TETE BOMBEE / 1.415-151.0 / -251.0	6.303-122.0	8
13	STRAHLROHR VP / JET PIPE / LANCE D'INCENDIE / 1.415-151.0 / -251.0	5.029-842.0	1
14	O-RING 18,0 X 2,0 / GASKET / BAQUE D'ETANCHEITE / 1.415-151.0 / -251.0	6.362-534.0	1
15	DUESENKOPF VP026 / NOZZLE CAP / BUSE / 1.415-151.0 / -251.0	4.762-270.0	1

"=> xxxxxx" = bis Werknummer / up to serial No. / jusqu' au No. de fabr. / "xxxxxx =>" = ab Werknummer / from serial No. / a partir du No. de fabr. /